

4.8 four point eight

Montageanleitung Tische **B2460 - B4800**

Assembly instructions tables **W2460 - W4800**

Notice de montage Table **L2460 - P4800**

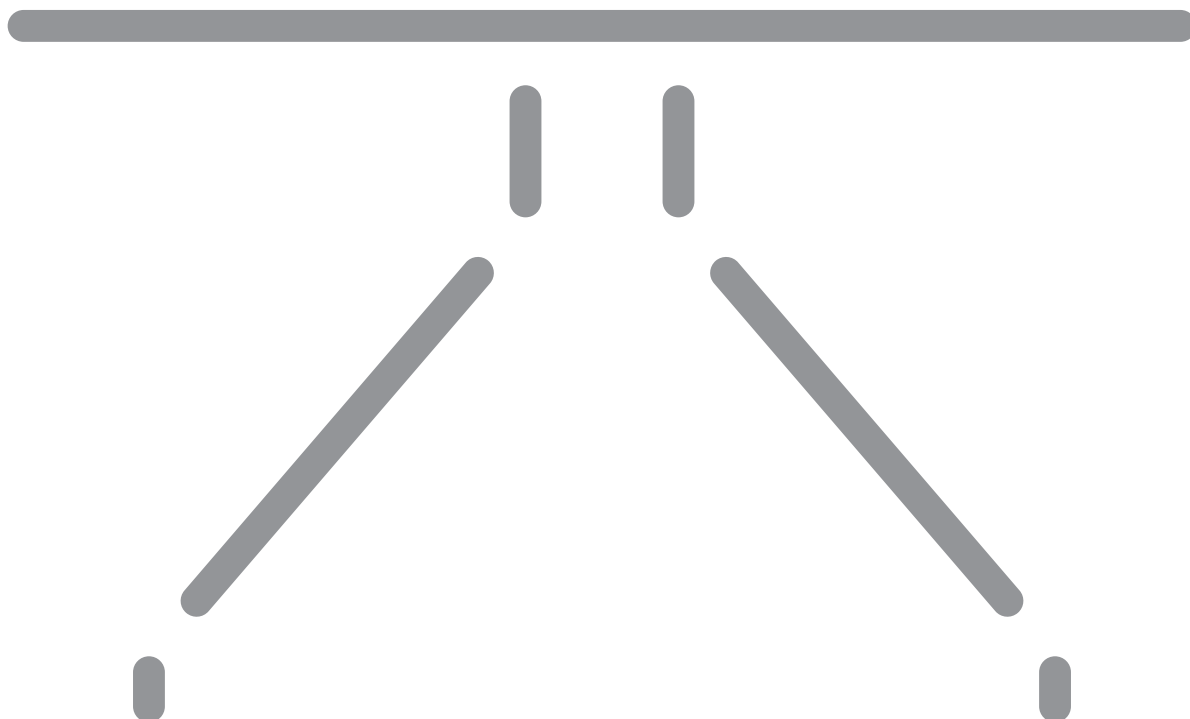

4.8 four point eight

System- und Komponentenübersicht

System and component overview

Aperçu des éléments du système

1.3

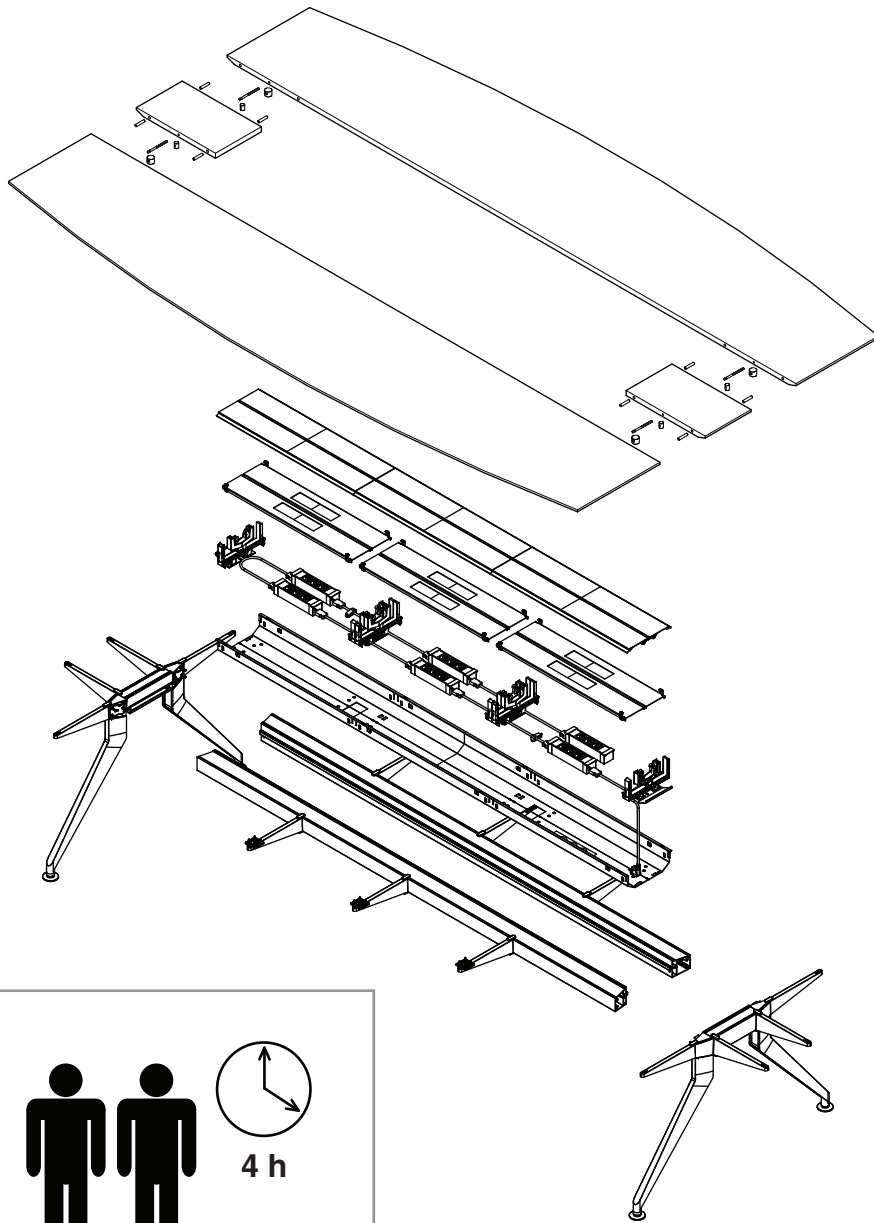

benötigte Werkzeuge
Tools required
Outils nécessaires

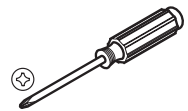

PZ1

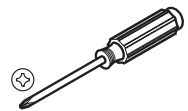

PZ2

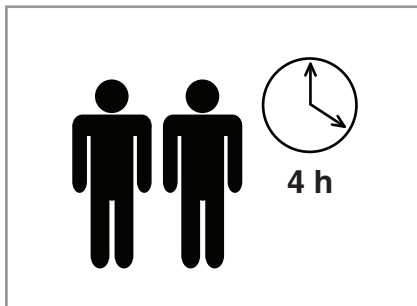
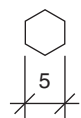
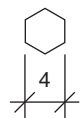

4.8 four point eight

Montage Tische B2460 - B4800

Assembly tables W2460 - W4800

Notice de montage Table L2460 - P4800

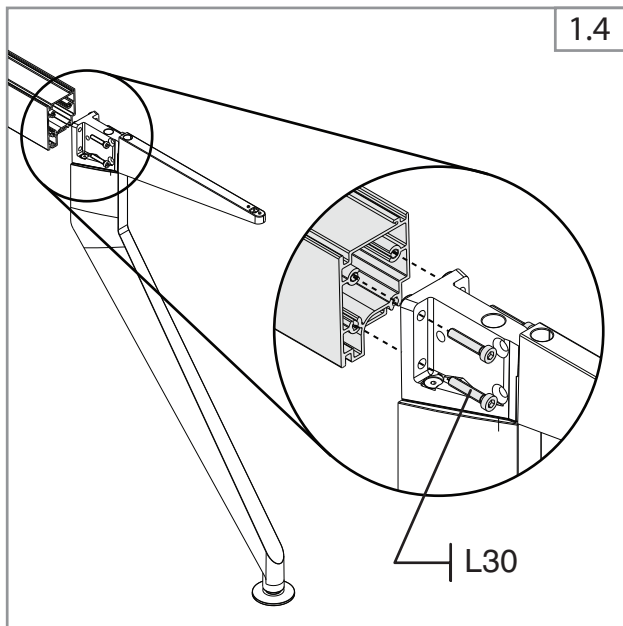

FüÙe mit Langstraverse verschrauben 8 Nm
Screw legs to bars of table depth 8 Nm
Visser les pieds sur les traverses 8 Nm

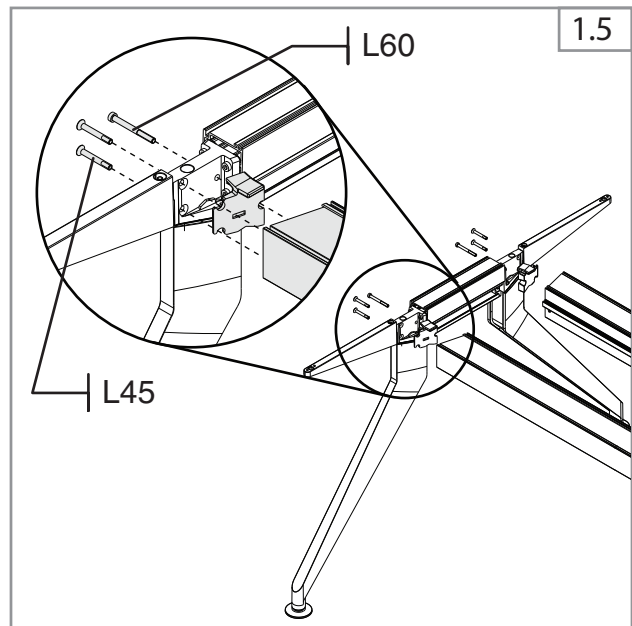

Distanzhalter anbringen und Quertraversen festschrauben 8 Nm
Position levelling chocks leg/bar and screw horizontal bars
to side frames 8 Nm
Monter les cales et visser les traverses 8 Nm

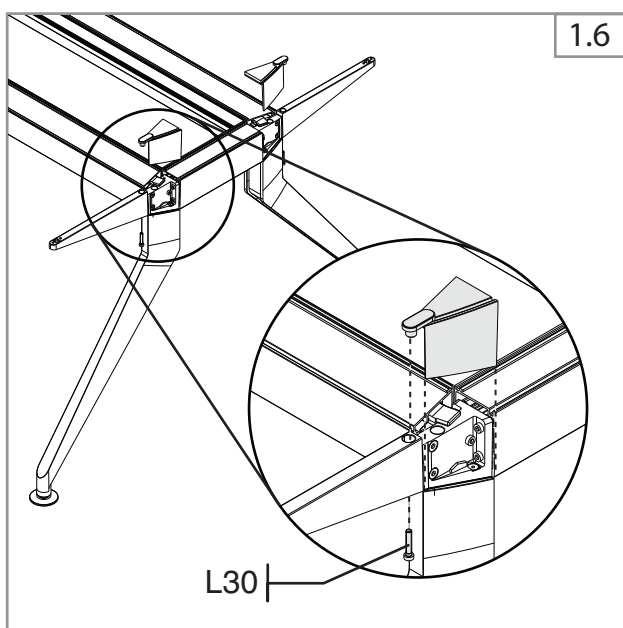

Abdeckkappen einstecken und festschrauben 5 Nm
Position and screw covers of cantilevers 5 Nm
Monter et visser les cache bras support 5 Nm

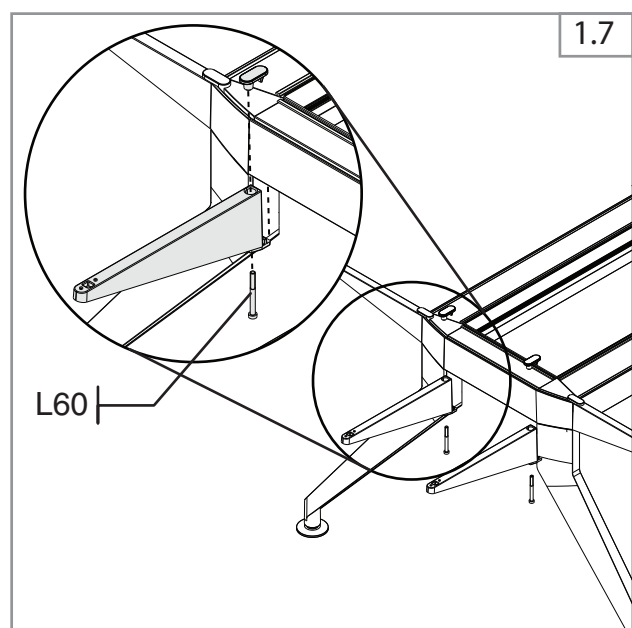

Stirnseitige Kragarme festschrauben 5 Nm
Screw cantilevers to bars of table depth 5 Nm
Visser les bras support sur les traverses 5 Nm

4.8 four point eight

System- und Komponentenübersicht

System and component overview

1.8

Table W2460

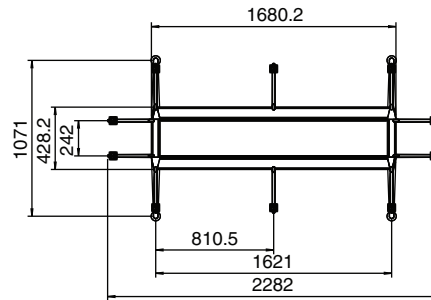

Table W3240

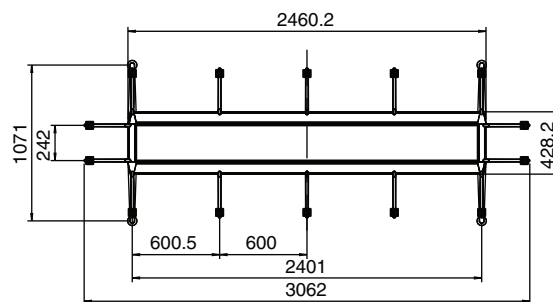

Table W4020

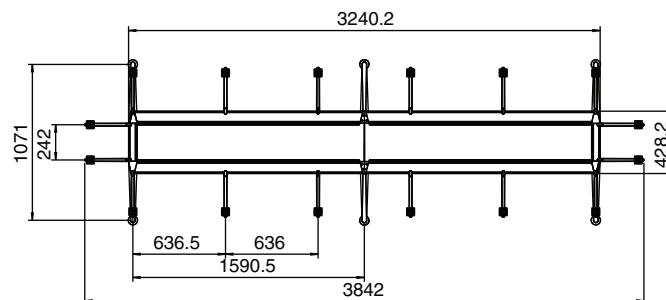
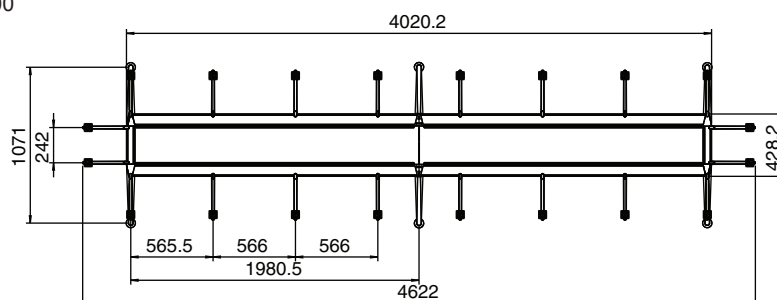

Table W4800



Position längsseitige Kragarme
 Position cantilevers at horizontal bar
 Position des bras support sur le longeron

4.8 four point eight

Montage Tische B2460 - B4800

Assembly tables W2460 - W4800

Notice de montage Table L2460 - P4800

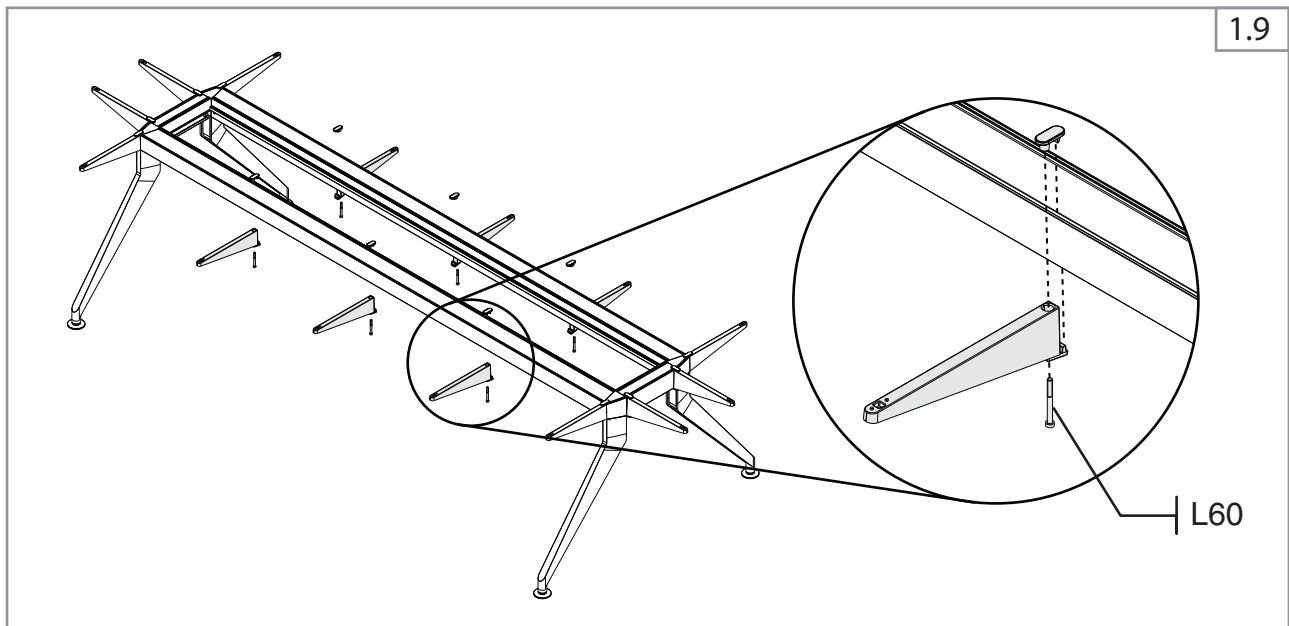

Längsseitige Kragarme festschrauben 5 Nm.
Screw cantilevers to horizontal bars 5 Nm.
Visser les bras support sur les longerons 5 Nm.

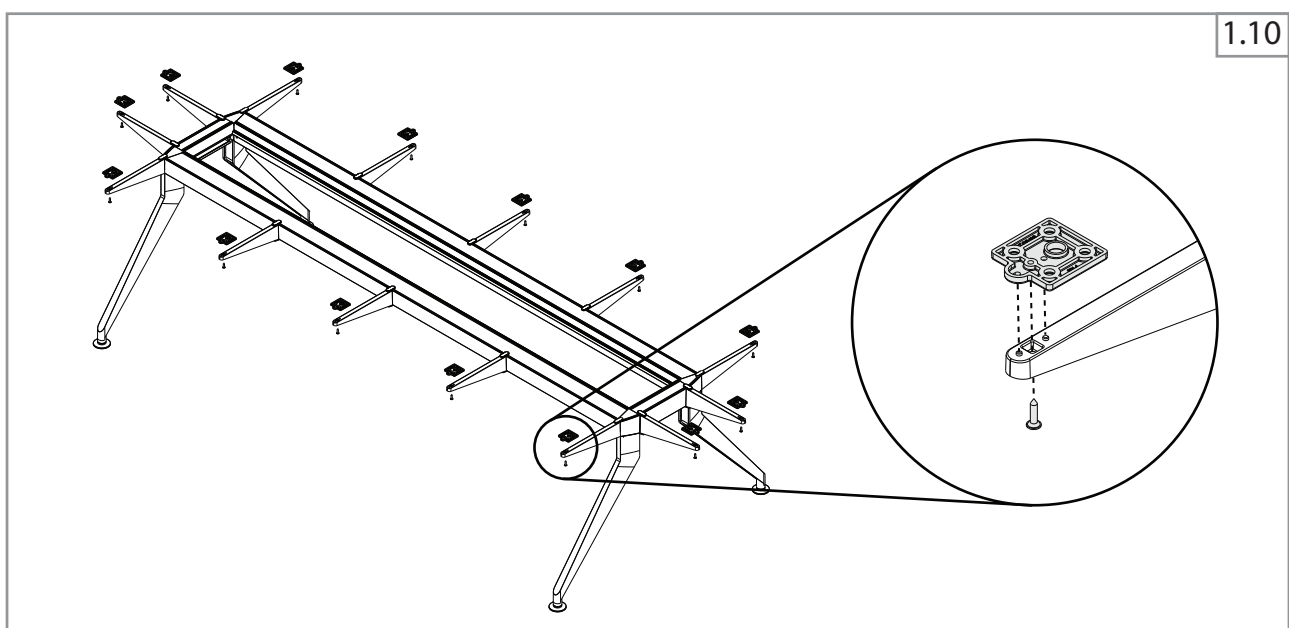

Plattenverbinder festschrauben
Screw top adapters to cantilevers
Visser les adaptateurs plateau sur les bras support

4.8 four point eight

Montage Tische B2460 - B4800

Assembly tables W2460 - W4800

Notice de montage Table L2460 - P4800

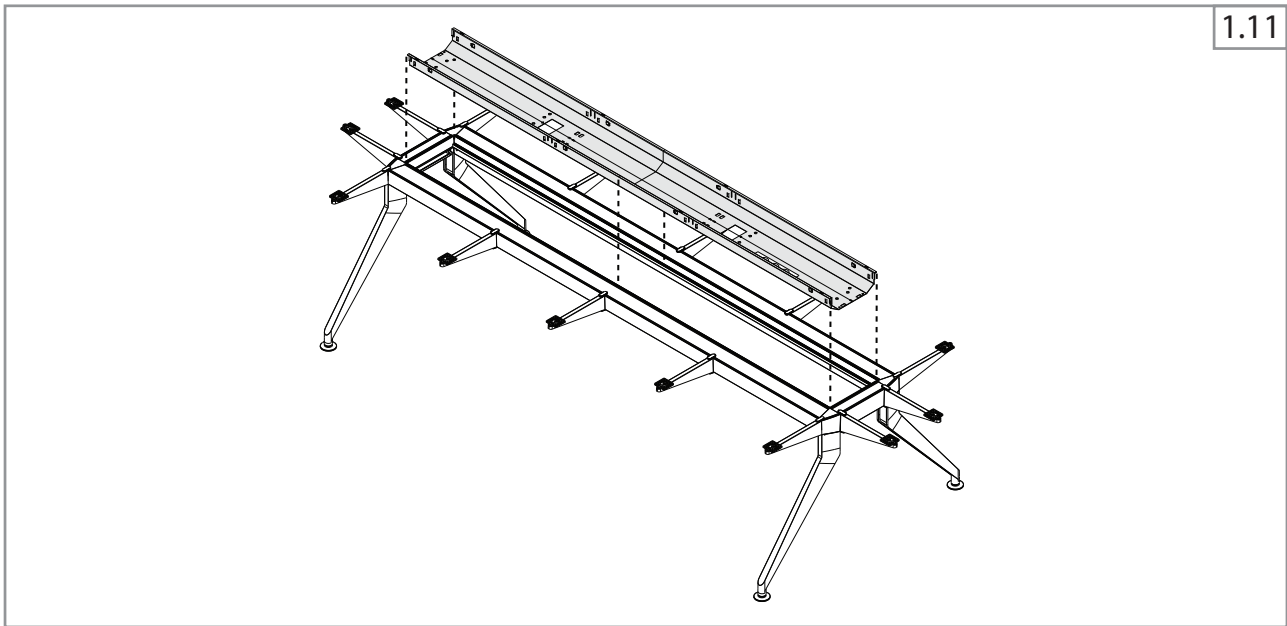

1.11

Kabelkanal einsetzen
Position cable tray into desk structure
Monter la goulotte

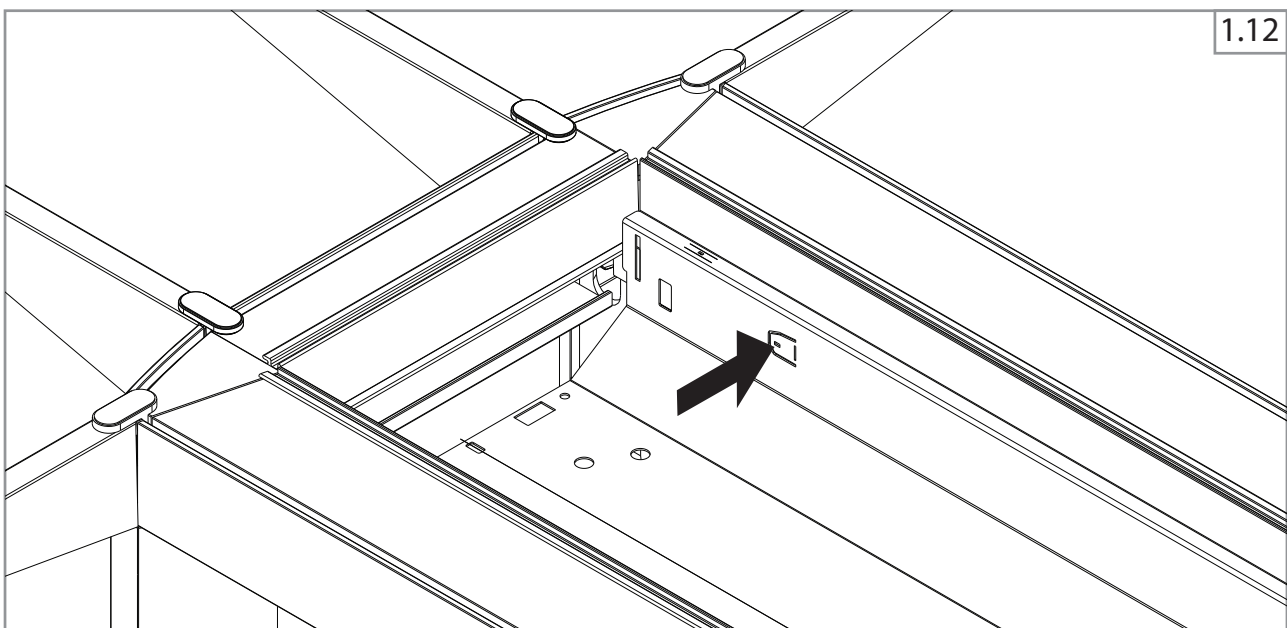

1.12

Zum fixieren des Kabelkanals Laschen eindrücken
Push tongues for cable tray fixation
Fixer la goulotte à l'aide de la languette

4.8 four point eight

Montage Tische B2460 - B4800

Assembly tables W2460 - W4800

Notice de montage Table L2460 - P4800

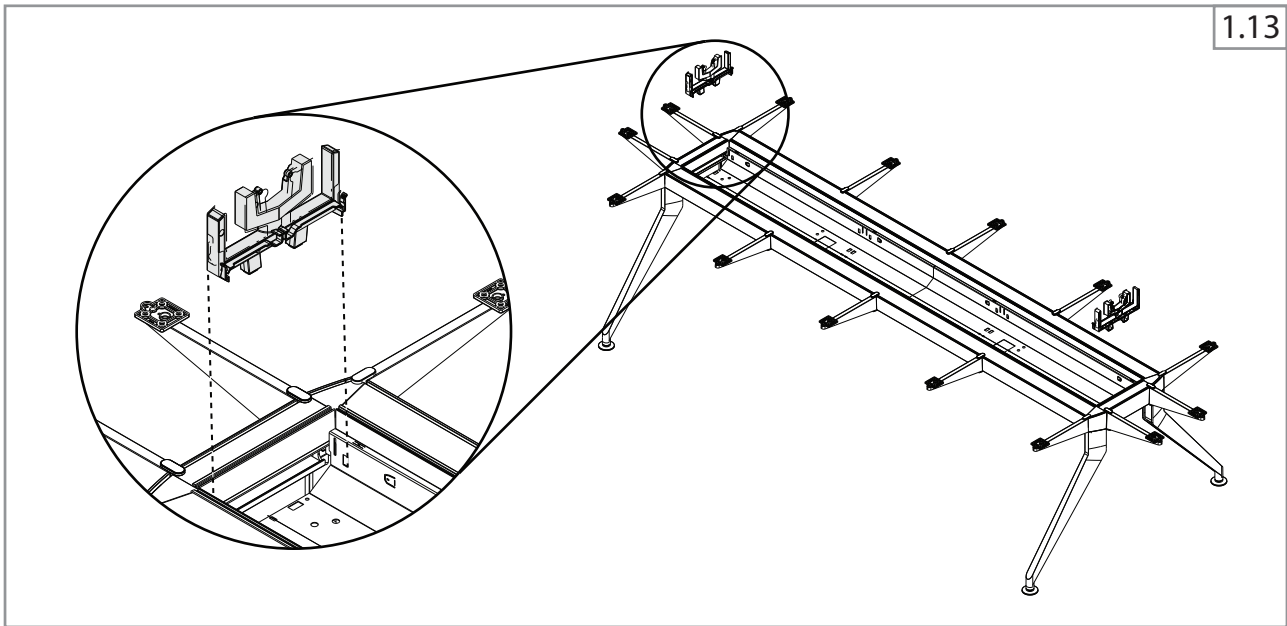

Kunststoffbrücken einsetzen
Position plastic bridge
Monter les ponts plastiques

4.8 four point eight

Montage Tische B2460 - B4800

Assembly tables W2460 - W4800

Notice de montage Table L2460 - P4800

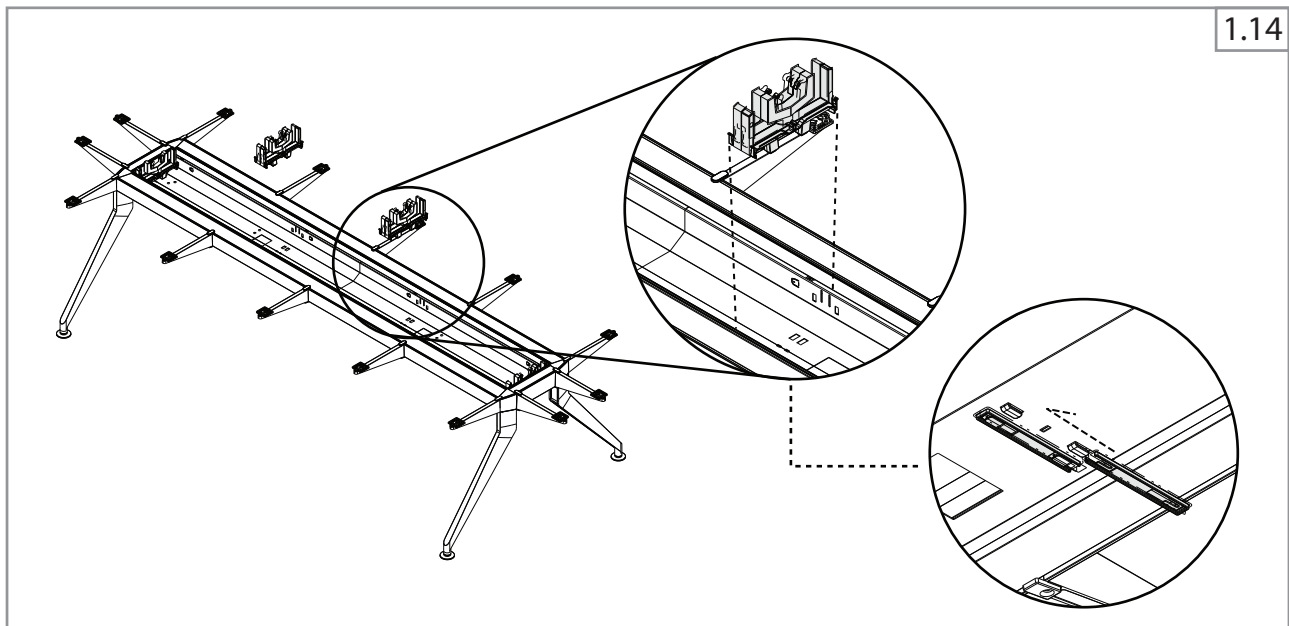

1.14

Mittige Kunststoffbrücken mit Kunststoffleiste sichern
 Fasten center plastic bridges with safety bracket
 Fixer les ponts plastiques du milieu avec la baquette de sécurité

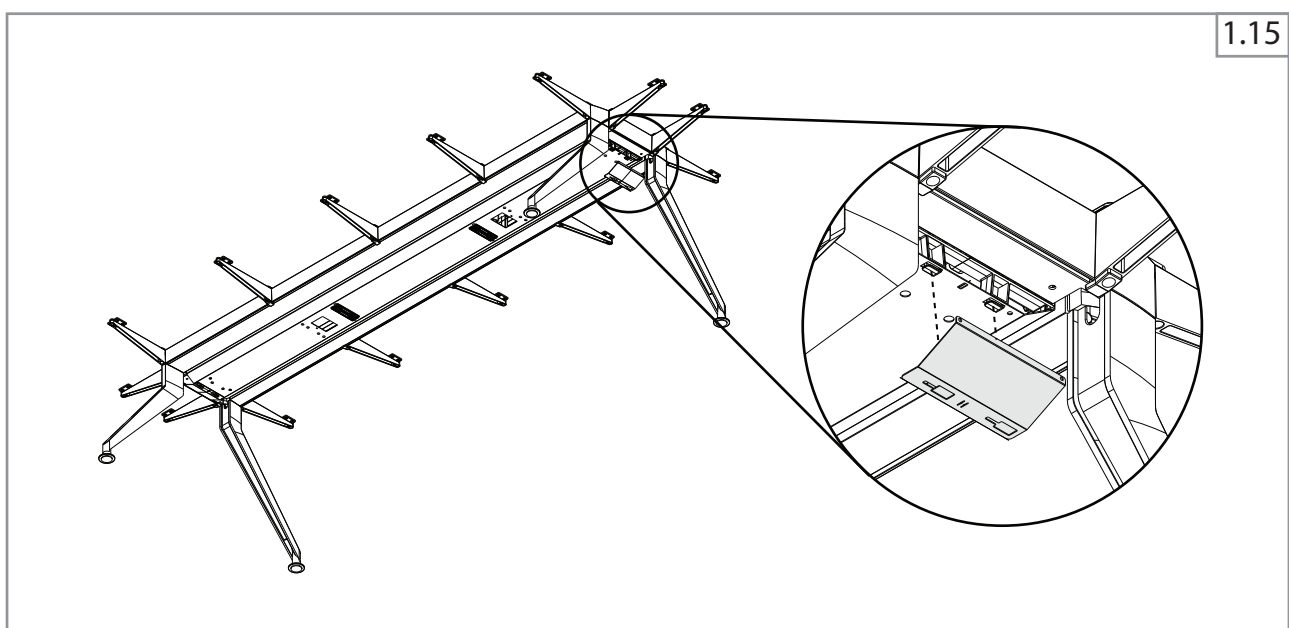

1.15

Kunststoffbrücken an Kabelkanalenden mit Blechabdeckung sichern
 Fasten plastic bridges at end of cable tray with end cover
 Fixer les ponts plastiques en bout de la goulotte avec le cache

4.8 four point eight

Montage Tische B2460 - B4800

Assembly tables W2460 - W4800

Notice de montage Table L2460 - P4800

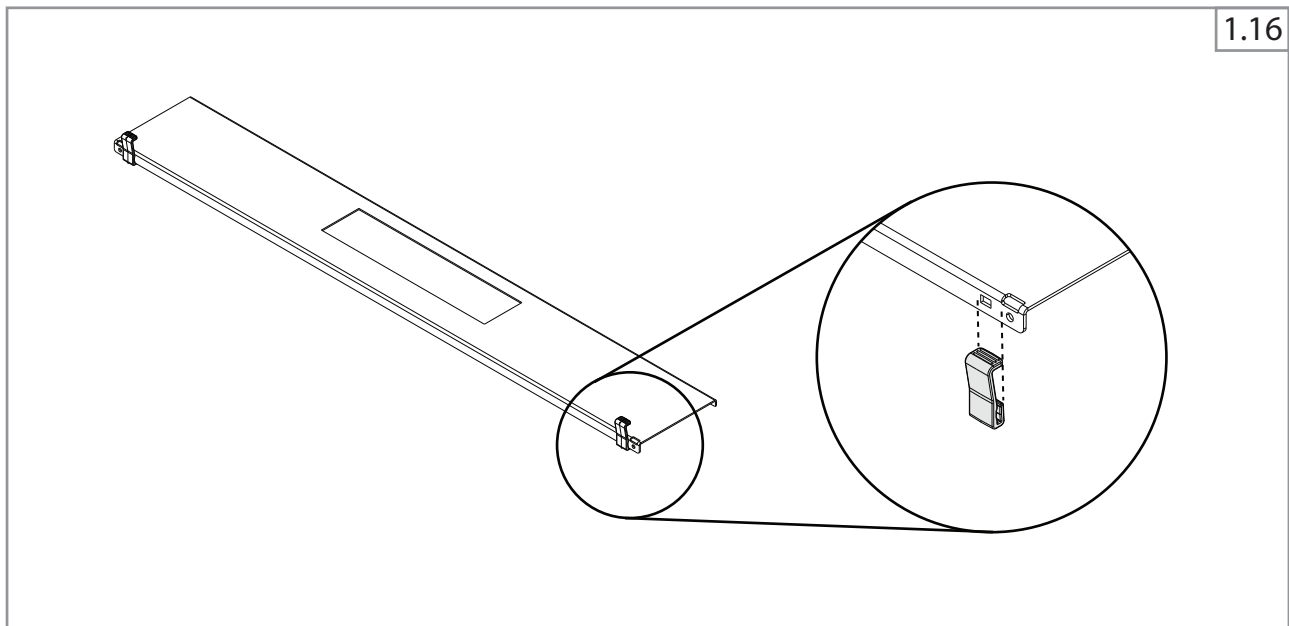

1.16

Kunststoffgriffe am Zwischenboden einsetzen
Position handle for cable tray base on it
Monter les poignées d'extraction sur le fond amovible

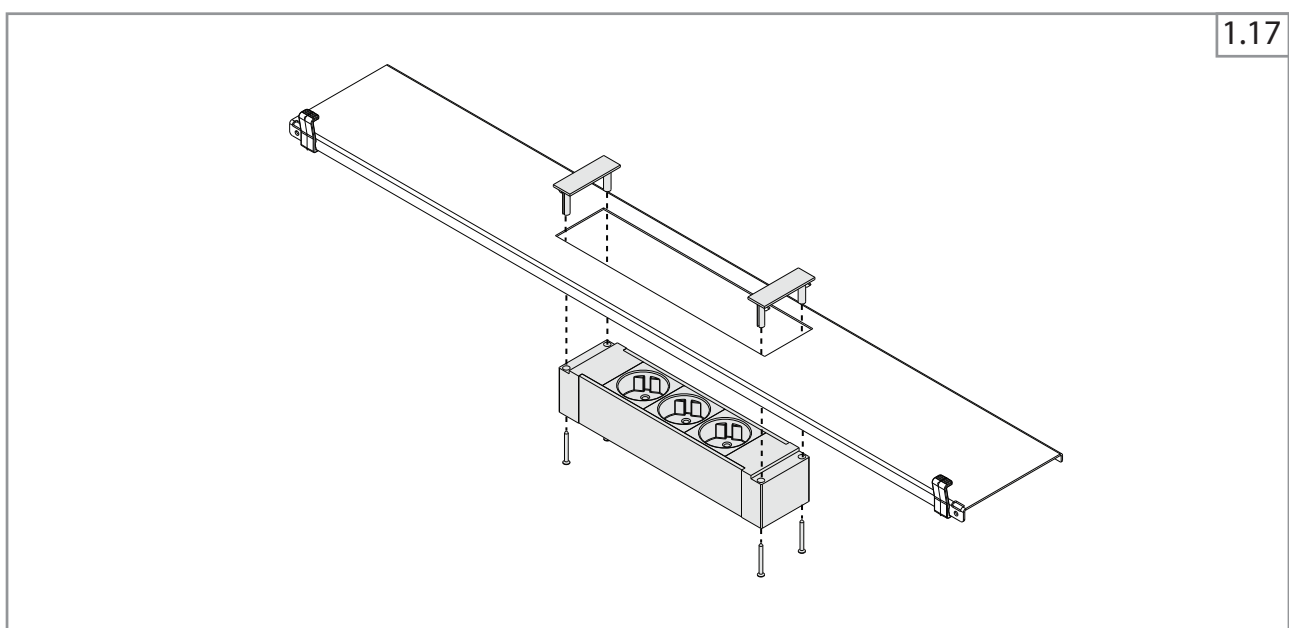

1.17

Steckdosenleisten im Zwischenboden einsetzen und festschrauben
Position and screw power sockets into cable tray base
Monter et visser les boîtiers 3 prises sur le fond amovible

4.8 four point eight

Montage Tische B2460 - B4800

Assembly tables W2460 - W4800

Notice de montage Table L2460 - P4800

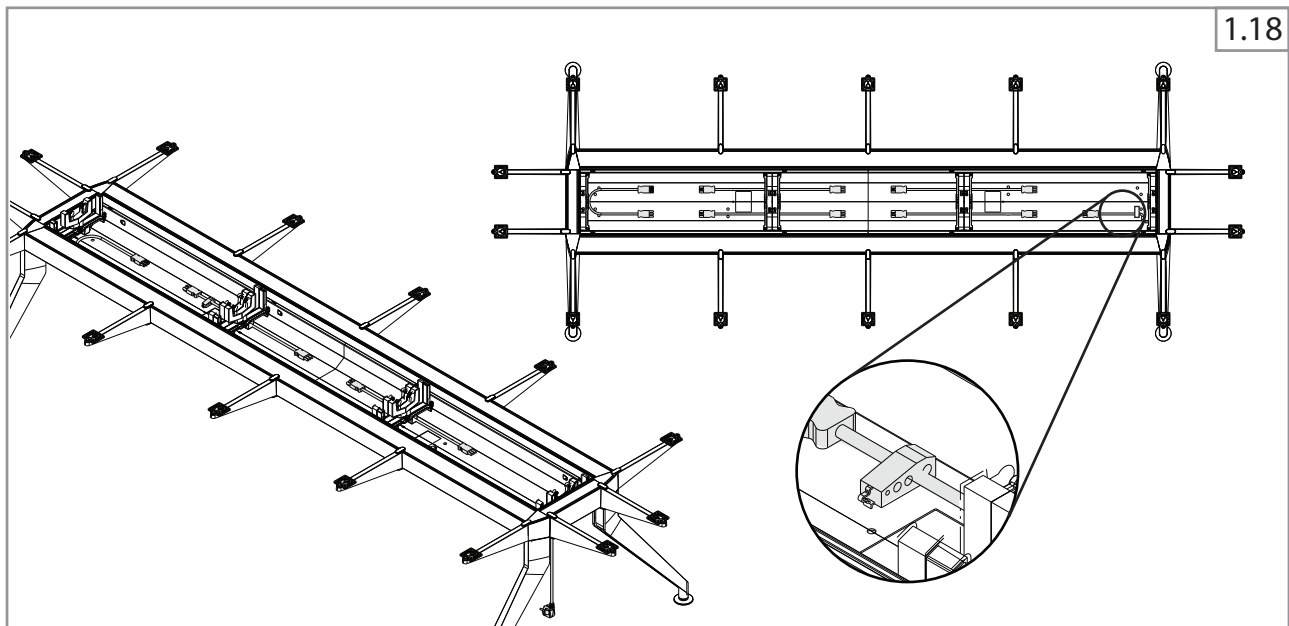

Zuleitungs- und Verbindungskabel einlegen und Zuleitung mit Zugentlastung sichern
 Position power and connection cables into cable tray and fasten power cables with cable anchorages
 Poser les câbles d'alimentation et de liaison et fixer le câble d'alimentation avec la sécurité anti-traction

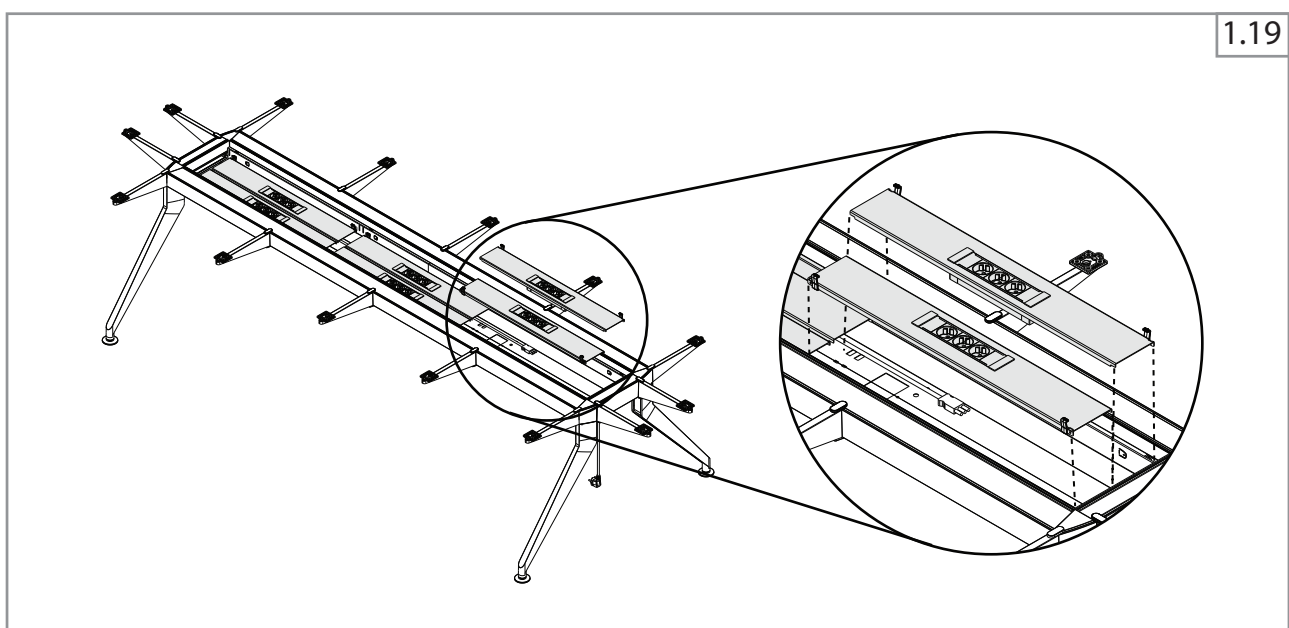

Zwischenboden in Kabelkanal einsetzen
 Position cable tray base into cable tray
 Poser le fond amovible dans la goulotte

4.8 four point eight

Montage Tische B2460 - B4800

Assembly tables W2460 - W4800

Notice de montage Table L2460 - P4800

1.20

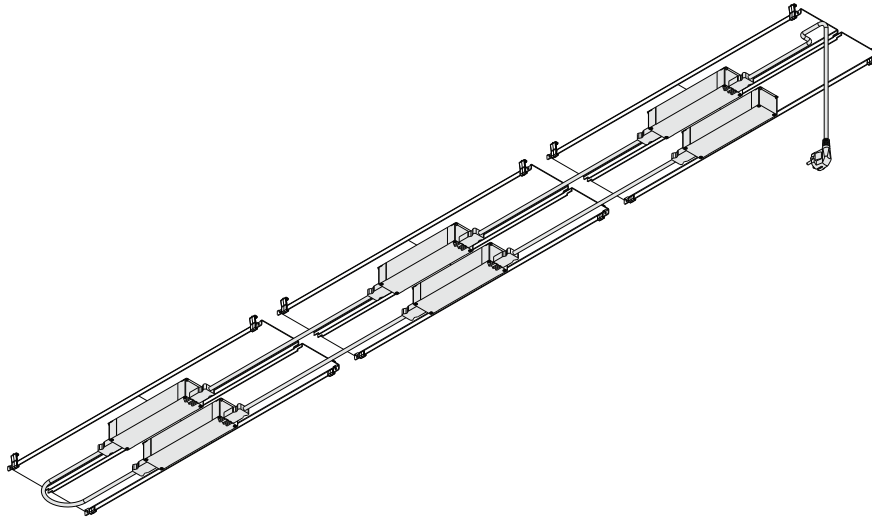

Steckdosenleisten mit Kabeln verbinden
Connect power sockets with cables
Brancher les câbles aux boîtiers 3 prises

1.21

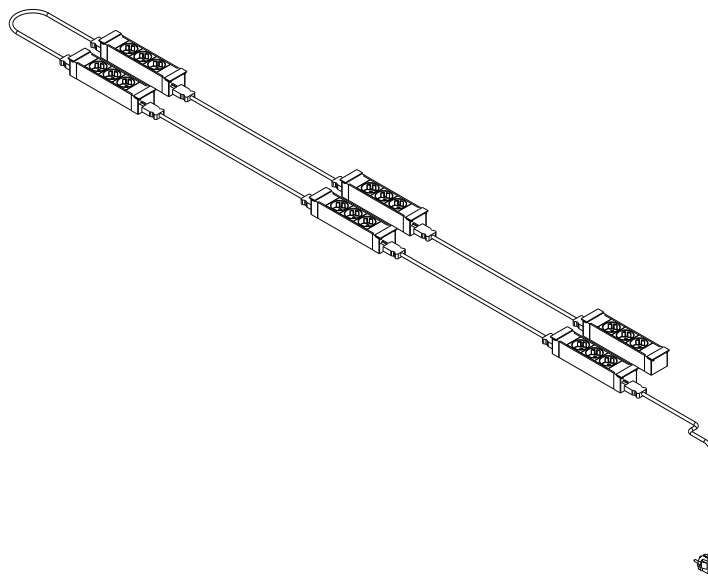

Sicherheitshinweis: max. 6 dreifach-Steckdosen pro Zuleitung
Safety instruction: max. 6 triple power sockets per power cable
Attention : maxi 6 boîtiers 3 prises par câble d'alimentation

4.8 four point eight

Montage Tische B2460 - B4800

Assembly tables W2460 - W4800

Notice de montage Table L2460 - P4800

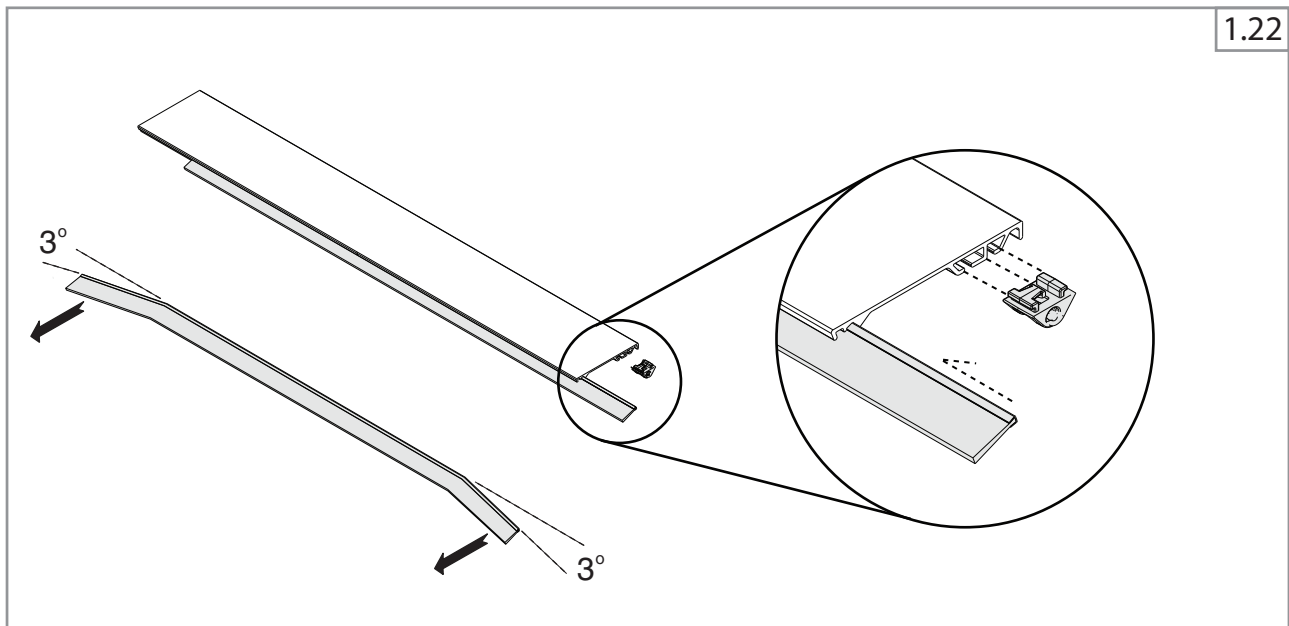

Kunststoffgelenke und Besen an Kabelkanalklappe einsetzen (leichtes verbiegen verbessert den Halt des Besens)
 Position hinges and bristle-brushes to cable tray flaps (slight bending of the brush supports permanent positioning)
 Monter charnières + brosse couvre-joint sur le couvercle (courber légèrement la brosse pour un meilleur maintien)

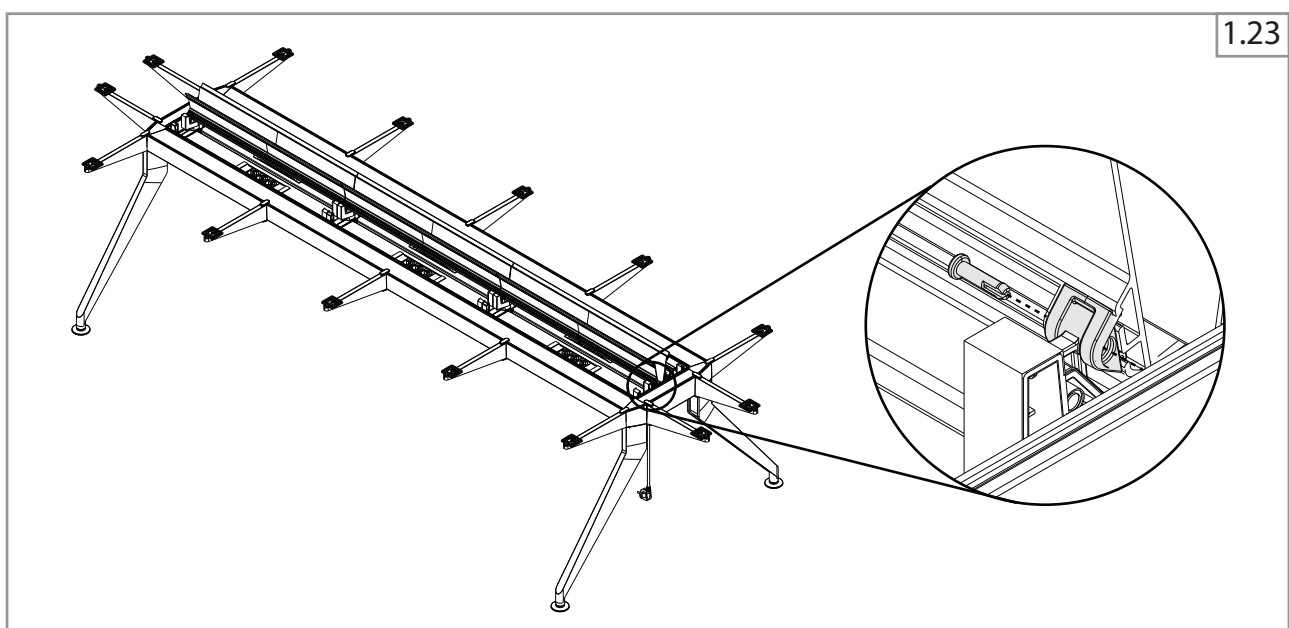

Kabelkanalklappen an Kunststoffbrücken positionieren und mit Sicherungsstiften befestigen
 Fasten cable tray flaps to plastic bridges with safety pin
 Fixer les couvercles de goulotte sur les ponts plastiques avec la goupille de sécurité

4.8 four point eight

Montage Tische B2460 - B4800

Assembly tables W2460 - W4800

Notice de montage Table L2460 - P4800

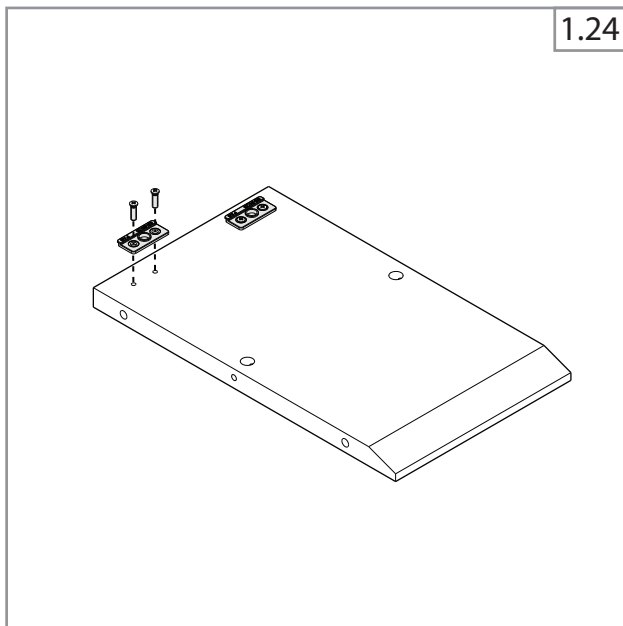

Z-Adapter festschrauben
Screw z-adapters
Visser les adaptateurs Z

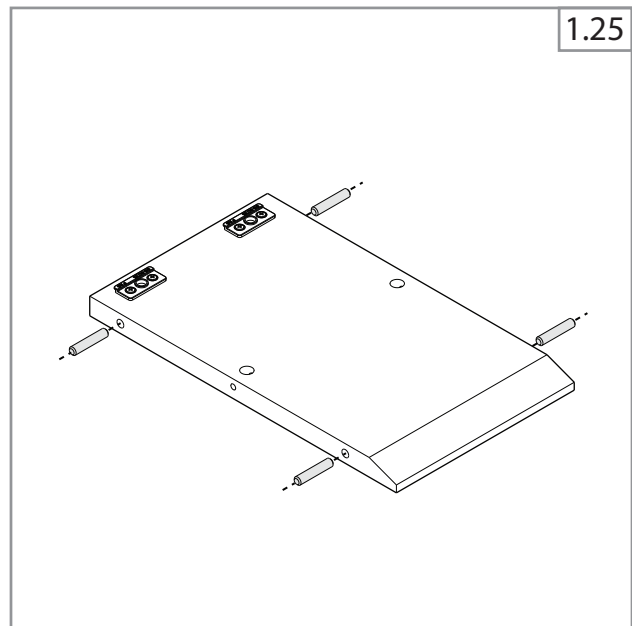

Holzdübel in Einfüllplatten einschlagen
Press wooden dowels into filler tops
Enfoncer les chevilles en bois dans les plans de jonction

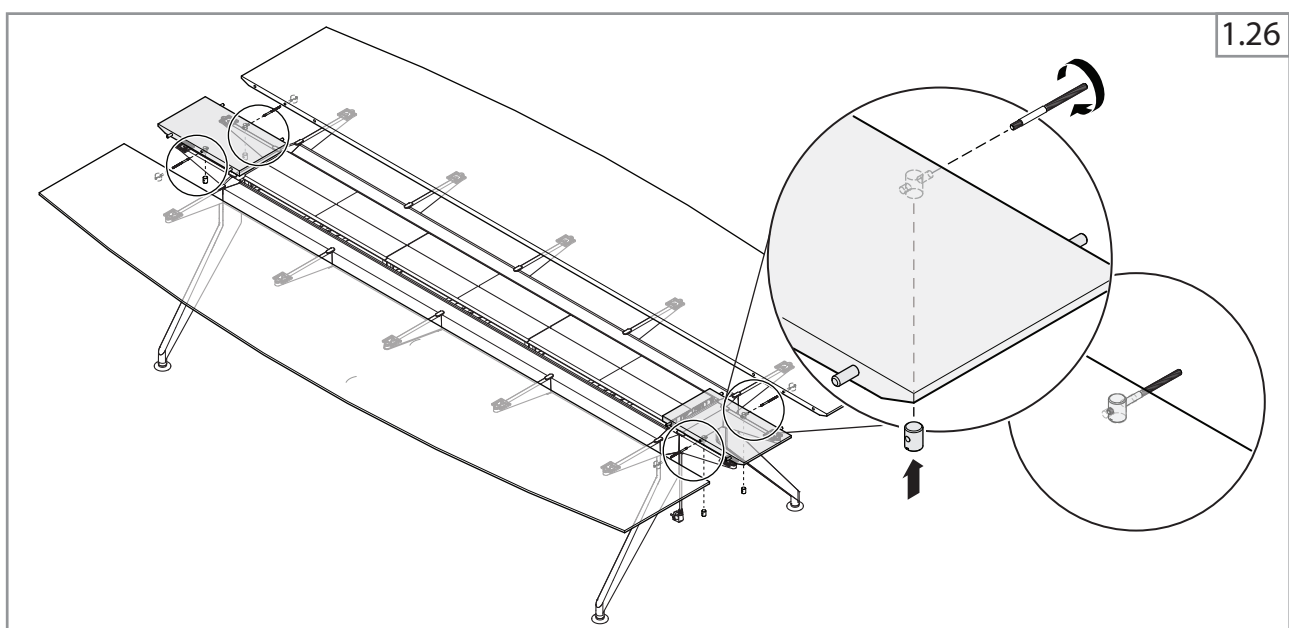

Verbindungsbeschlag in Einfüllplatte eindrücken und Verbindungszapfen festschrauben. Einfüllplatte an erster Hauptplatte ansetzen
Push the levelling chock bar into the filler top and tighten the fastening adapter. Join the filler top to the first main top.
Enfoncer l'élément de liaison dans le plan de jonction et visser l'adaptateur de fixation. Fixer le plan de jonction sur le premier plateau

4.8 four point eight

Montage Tische B2460 - B4800

Assembly tables W2460 - W4800

Notice de montage Table L2460 - P4800

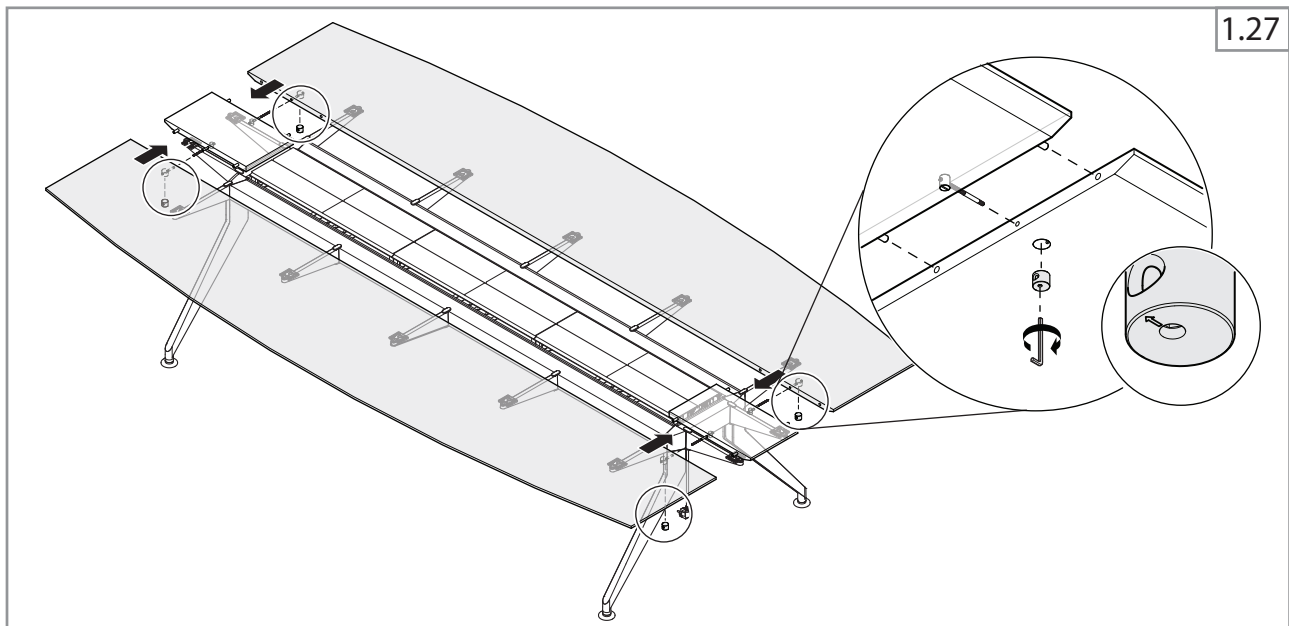

Gegenstück des Verbindungsbeschlages in Hauptplatte eindrücken und durch festschrauben mit Einfüllplatte verbinden.
Push the counterpart of the levelling chock bar into the main top and connect it to the filler top by tightening it.
Enfoncer la contrepartie de l'élément de liaison dans le plateau et le visser le plan de jonction.

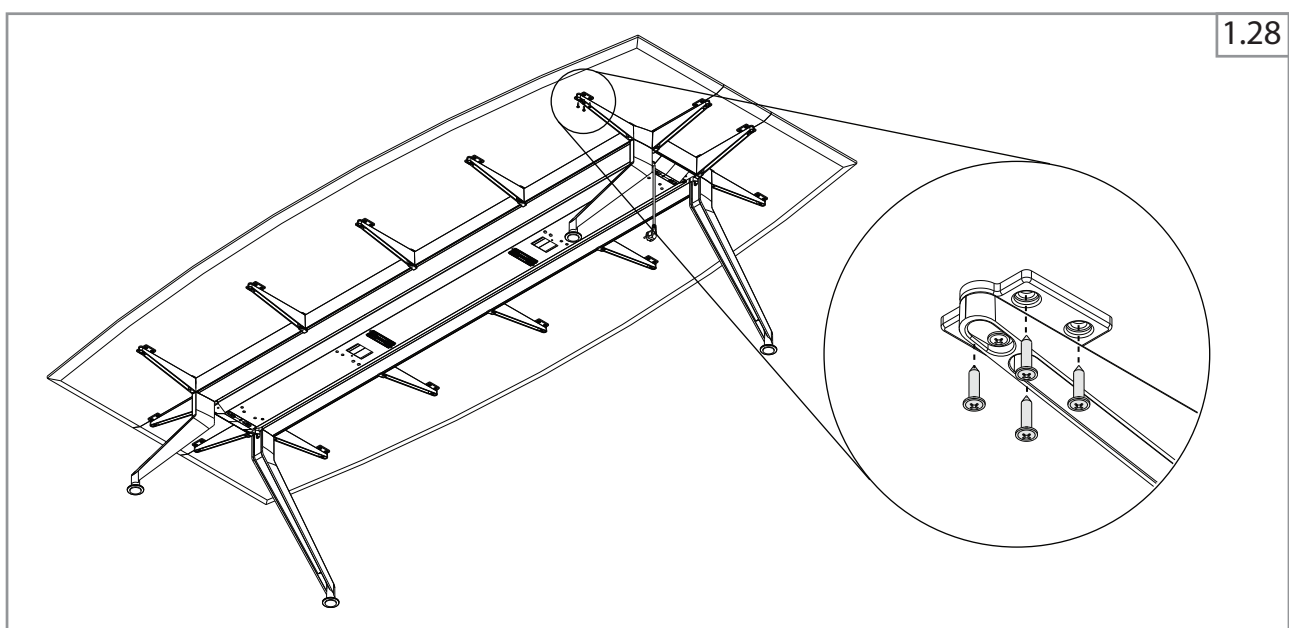

Plattenkombination zum Kabelkanal ausrichten und Platten an Plattenverbindern festschrauben
Align combination of top to cable tray and screw tops to top adapters
Aligner l'ensemble des plans sur la goulotte et visser les plateaux sur les adaptateurs